



From small signs to large banners, this 64 in/1626 mm printer is the perfect tool for any print or sign shop. Experience a breakthrough price/performance combination with this low-solvent large-format device for a wide range of long-lasting applications.



Print more, pay less

- **Heavy-duty HP printheads and HP supplies for maximum productivity.** Experience high-speed printing with six heavy-duty Piezo printheads that come with 256 nozzles per printhead for a total of 1,536 nozzles. 500 ml, HP 780 ink cartridges are designed to meet your usage needs.
- **Produce striking signs with this in-the-box RIP:** **Onyx® SignEZ v7.0 for HP Designjet.** Providing you with the essential tools to get started, this software RIP is easy to use and navigate, has basic color correction tools, basic nesting and tiling, and support for contour cutting workflow.
- **Enable long, unattended print runs for improved productivity with optional Take-Up Reel Kit.** This optional accessory enables busy print and sign shop employees to be more productive by maximizing unattended printing with four winding modes: slack/face-in, slack/face-out, tight/face-in, and tight/face-out.
- **Minimize your costs and get lasting output on uncoated media.** Count on excellent quality output on a range of low cost, uncoated materials, such as adhesive vinyls, films, banner stocks, papers, and fabrics.

Vivid colors with excellent durability

- **Wow your clients with vivid color output that shines brightly.** Create signs, banners, and large graphics with such vivid color, they radiate success. Sophisticated HP "low-solvent"⁽¹⁾ ink formulations and printhead technology enable a higher concentration of colorants in the inks to produce a wider gamut of rich, saturated color. The result - more vivid color for high impact image quality.
- **HP low-solvent inks - excellent durability without lamination on low-cost, uncoated media.** Designed with the HP Designjet 8000s Printers, HP low-solvent ink formulations produce durable prints that resist fading for up to three years without lamination and are scratch, smear, and crack resistant.⁽²⁾
- **Premium image quality - HP printing materials designed with HP low-solvent inks.** With HP Premium Scrim Banner, HP Universal Scrim Banner, HP Premium Backlit Film, HP Blue Back Satin Billboard Paper, HP Satin Canvas, and HP Translucent PVC Display Film, get premium image quality and high opacity.

A comprehensive and easy to use HP solution

- **A remarkably user-friendly solution.** No need for highly-skilled operators. Conveniences such as the manual cutter and easy media loading system ensure user-friendly operation. Maintenance and cleaning is hassle-free thanks to the easily accessible, self-contained tools and the clear instructions included.

- **At HP, we make it easy for you to grow your business with this comprehensive, scalable solution.** Not only does HP deliver a reliable, top-quality printer, we also provide the optional accessories you need as your business grows to produce multiple signage applications - including a Take-Up Reel Kit, High Speed Dryer, and Air Purifier System - easily and efficiently.
- **Purchase your large-format printer and the supplies you need from your one-stop shop: HP.** Getting your business up and running couldn't be easier when you choose HP. Purchase the hardware and the supplies you need - including HP ink supplies and HP printing materials - from a single vendor.

Safety and support-at HP, your needs come first

- **Have a clean, safe print environment with an integrated air purifier created for HP Designjets.** This printer-connected system uses a sealed, carbon-activated filter and high-powered fan to filter air at a rate consistent with the print speed and the number of volatile organic compounds released during the printing process.
- **HP guidelines help make HP low-solvent ink printing safe, productive, and easy.** Following HP's installation and use guidelines helps you achieve a reliable and productive low-solvent ink printing solution and helps you address environmental, health, and safety questions about printing with HP low-solvent inks. To learn more, visit www.hp.com/go/ehs.
- **Designed together for HP quality and reliability.** The HP Designjet printing system - printers, low-solvent inks, ink cartridges, printheads, and printing material - is engineered to work with precision and must meet strict HP quality standards. Reliable operation saves you time and improves your productivity.
- **HP offers the cleaning supplies and replacement ink cartridges needed to maintain your system.** HP training and guidelines help you implement environmentally responsible and safe practices for the purchase, installation, operation, handling, and maintenance of HP low-solvent printing supplies.
- **Experience peace of mind, knowing you're covered with HP's award-winning service and support.** HP's customer service and support backs every product with fast, knowledgeable online e-Support available 24/7 at www.hp.com/support, and easy-to-access phone support provided by HP trained agents. Plus, you can enhance your warranty protection with the purchase of affordable HP Care Pack Services.



Manual cutter



Cleaning station and self-contained tools



500 ml HP Ink Supplies



Easy media loading

⁽¹⁾ HP "low-solvent" inks are defined according to what is currently known in the industry as low-solvent inks.

⁽²⁾ Image permanence and application durability under typical exposure in vertical display conditions and varies as environmental conditions change.

HP Designjet 8000sr Printer

1. Up to 64 in/1626 mm wide
2. Six HP 780 ink cartridges, 500 ml each
3. Interactive front panel
4. USB 2.0 Hi-speed connectivity
5. 3 Integrated heaters
6. Easy media-loading
7. Exhaust attachment for efficient removal of Volatile Organic Compounds (VOC) included in the printer box
8. Printhead height adjustable to 2 different positions
9. Manual cutter
10. Container for cleaning kit

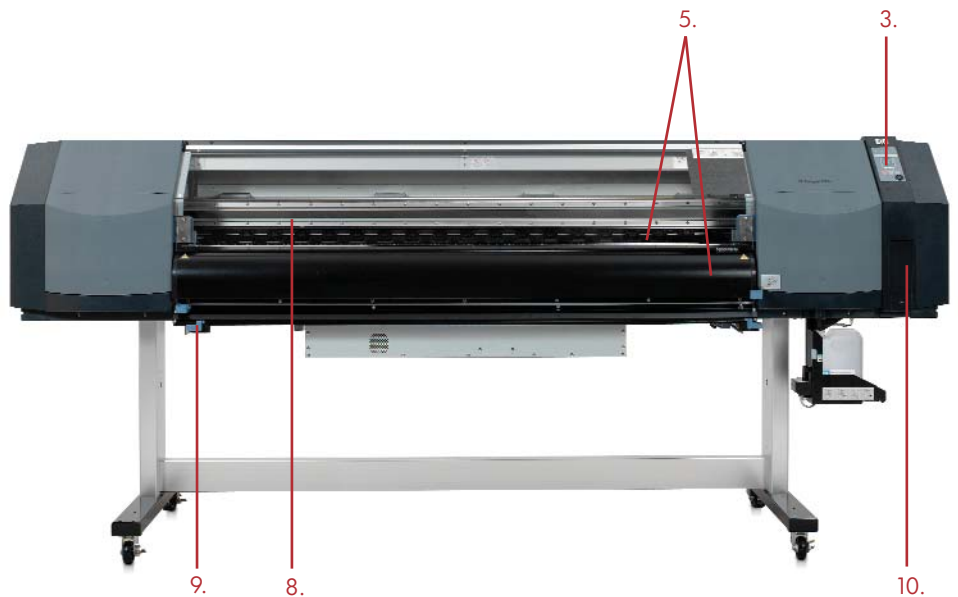
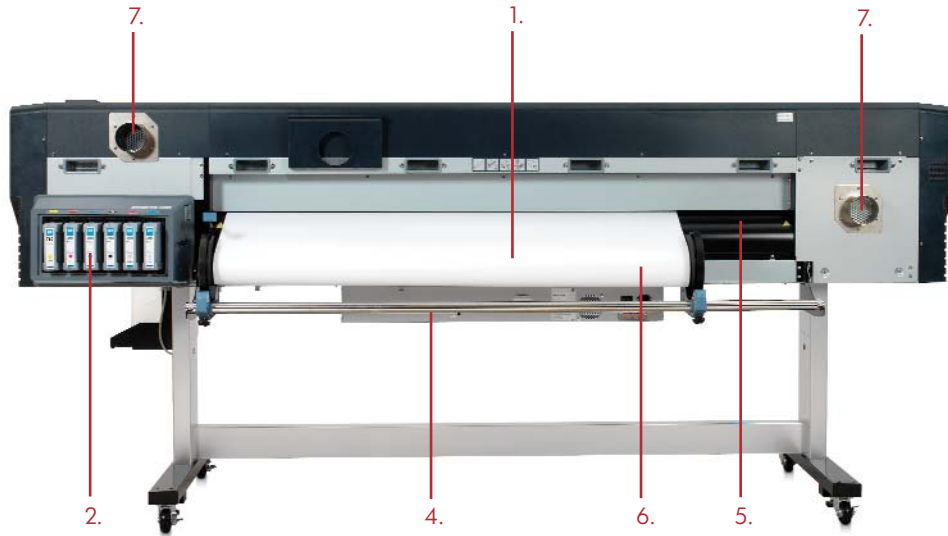

HP Designjet 8000sr Printer at a glance

HP Designjet 8000sr Printer

In the box

HP Designjet 8000s Printer,
Onyx® SignEZ v7.0 for HP Designjet*

*Onyx® SignEZ v7.0 for HP Designjet IS NOT available as a standalone accessory

Optional accessories

- HP Designjet Air Purifier System
- HP Designjet 8000s Take-Up Reel Kit
- HP Designjet High Speed Dryer
- Onyx® PosterShop® 7.0 for HP Designjet
- HP Designjet 8000s Cutter Blade Kit
- HP Designjet APS filter

The HP Designjet 8000s Printer series, HP low-solvent ink cartridges, and printing material were all designed, engineered and tested together to ensure uncompromising reliability, image quality, durability, performance and ease of use. The total HP printing solution is composed of the following accessories:

HP Designjet 8000s Take-up Reel Kit

- **Print long runs or on long printing materials.** Does your shop have more to print than it can keep up with? Extend its periods of continuous, unattended printing. This take-up reel re-rolls printed media, allowing for long print runs - for example, overnight - and printing on long printing materials.
- **Rely on heavy-duty media feed and take-up system.** This accessory turns and winds up onto a reel printed media. Print long runs, on long printing materials, and easily handle completed prints. Sturdy reel supports four positions-slack/face-in, slack/faceout, tight/face-in, and tight/face-out.
- **Improve workplace efficiency.** With this media take-up reel, print and sign shop employees can make the most of their time and be more productive. Shops better meet client deadlines by maximizing unattended printing - even overnight - and efficiently collecting prints for finishing.



HP Designjet Air Purifier System

Put your confidence in HP. Add this air purifier system (APS) - specially designed for HP low-solvent inks - to your HP Designjet printer for highly efficient air filtration. The APS includes the tubes that connect to the printer. Count on HP for a clean, safe* print environment

- **Highly effective carbon filter removes hazardous substances released from solvent inks.**
 - **Return cleaned air to the working area or divert it outside.** This air purification system is equipped with a standard sealing device, and collected pollutants are led automatically through the filter.
- Easily operate with front-panel display unit
- **Access air purification system data through a front-panel display unit.**
 - **Easily replace the filter through the front door on the system.**

* When used appropriately, according to the product's guidelines.

HP Designjet High Speed Dryer

Add this high-speed dryer to your HP Designjet 8000s Printer and accelerate drying time.

Improve productivity - dryer reduces drying time

- **Dry prints as quickly as the automatic take-up reel can roll them up.** With the high-speed dryer and take-up reel, you can complete jobs at a rate of up to 165 ft²/hour (15.3 m²/hour). The integrated dryer and take-up reel enable unattended print runs.

Easily operate high-speed dryer

- **Completely dry prints with user-adjustable heater and blower unit.** Use variable controls on top of the dryer unit to set the heater temperature and to adjust the fan airflow.
- **Dryer's off timer allows unattended drying for up to 12 hours**

Count on a dryer that was designed for safety

- **Built for high-volume, commercial print environments**



Onyx® PosterShop® 7.0 for HP Designjet

If you need to upgrade to a more powerful software RIP solution and color workflow, use this Onyx® PosterShop® RIP to print job after job of the best colors your printer can produce. Efficiently manage jobs and handle production with job preflight and printer queue tools.



Complete solution

HP Designjet 8000sr Printer



Technical specifications

Print speed	
High quality	44 f ² /hr (4.08 m ² /hr), color image on vinyl media
Normal	88 f ² /hr (8.17 m ² /hr), color image in vinyl media
Draft normal	110 f ² /hr (10.2 m ² /hr), color image on vinyl media
Fast	165 f ² /hr (15.3 m ² /hr), color image on vinyl media
Print resolution maximum	720 x 720 dpi
Print margins	
Normal	(Top x bottom x right x left): 0.2 x 0.2 x 0.2 x 0.2 in/5 x 5 x 5 x 5 mm
Using paper edge guard	(Top x bottom x right x left): 0.2 x 0.4 x 0.2 x 0.4 in/5 x 10 x 5 x 10 mm
Memory	192 MB
Media	
Handling	Sheetfeed, roll feed, optional take-up reel, manual cutter
Types	Paper, self-adhesive vinyl, banner scrim, films, fabrics
Thickness	0.002 - 0.024 in/0.07 - 0.63 mm
Printhead height	0.826 to 0.102 in/2.1 to 2.6 mm
Maximum width	64 in/1626 mm
Maximum roll weight	52.9 lb/24 kg
Printing	
Technology	Piezo-electric inkjet heads
Technology resolution	720 x 720 dpi
Print cartridge colors	Cyan, magenta, yellow, black, light cyan, light magenta
Ink types	HP low-solvent inks
Ink drop	12 pl
Ink cartridge size	500 ml
Nozzles	256 nozzles per head x 6 colors
Maximum print length	49 ft/15 m (RIP dependent)
Print accuracy	± 0.3 % or ± 5 mm whichever is larger
Heater	
Integrated	3 independent heating systems
Heater locations	Front, print and rear areas
Heater settable temperature	59 to 131 °F/ 15 to 55 °C
Interfaces (Standard)	USB 2.0 Hi-speed
Dimensions (w x d x h)	
Printer	112 x 32.6 x 49.4 in/2846 x 830 x 1255 mm
Shipping	116.5 x 38.5 x 36.6 in/2960 x 980 x 930 mm
Weight	
Printer	478 lb/217 kg
Shipping	708 lb/321 kg
What's in the box	
HP Designjet 8000sr Printer	HP Designjet 8000s Printer, USB cable, coated paper, cleaning kit, ink cartridges (500 ml x 6), ink box cover, printhead set (6), waste-ink bottle holder, waste ink bottle (2), exhaust attachment kit, stand assembly including screws and open ended spanner, pipe for media support, media support holder (2), media support stay (2), screws and screwdriver for assembly, power cord, CD (containing user guide, legal information and maintenance guide), hard copy users guide & maintenance guide, 3 inch paper roll flanges (2), paper roll flange spacer (2), Onyx [®] SignEZ v7.0

Minimum PC operating system requirements for the Onyx[®] SignEZ 7.0 and the Onyx[®] PosterShop[®] 7.0 for HP Designjet Windows XP Pro with latest SP, Windows 2000 Pro with latest SP, Intel Pentium 3 or higher, Athlon, 2.5 GHz or higher, Dual CPC for multiple RIPs, one 80 GB Hard Drive (preferably two 80 GB Hard Drives for optimal performance), 1 GB RAM per CPU, 1280 x 768 16 bit color display, one USB Port required for security key, DVDROM drive

Environmental ranges	
Recommended operating temperature	59 to 86 °F/15 to 30 °C
Storage temperature	41 to 95 °F/5 to 35 °C
Recommended humidity range	30 to 70% RH
Acoustic	
Sound pressure, active	67.9 dB (A)
Sound pressure, standby	50.2 dB (A)
Power consumption	
Printer active	150 watts
Printer with Heater active	1350 watts
Printer standby	35 watts
Heater standby	2 watts
Power requirements	
Printer	100 to 120 VAC (+/- 10%), 50/60 Hz +/- 1 Hz, 1.3 amp; 230 VAC (+/- 10%), 50/60 Hz +/- 1Hz, 0.75 amp
Heater	100 to 120 VAC (+/- 10%), 50/60 Hz +/- 1Hz, 9.5 amp; 230 VAC (+/- 10%), 50/60 Hz +/- 1 Hz, 5.0 amp
Certification	
Safety certification	Compliant with IEC 60950, including EU LVD and EN60950, CSA certified for US and Canada, Mexico, NYCE, Argentina, IRAM, Singapore PSB, Russia VNIIS
Regulatory certification	Compliant with Class A requirements including EU (EMC Directive), USA (FCC rules), Canada (DoC), Australia (ACA), New Zealand (MoC), Japan (VCCI), Korea (MIC), Taiwan (BSMI)
Warranty	
Printer	One year system warranty
Printheads	One year warranty

© 2006 Hewlett-Packard Development Company, L.P. The information contained herein is subject to change without notice. The only warranties for HP products and services are set forth in the express warranty statements accompanying such products and services. Nothing herein should be construed as constituting an additional warranty. HP shall not be liable for technical or editorial errors or omissions contained herein.

For more information, visit our website at
www.hp.com/go/designjet8000s

4AA0-3029ENW

Accessories - technical specifications

HP Designjet Air Purifier System	
What's in the box	HP Designjet Air Purifying unit with 2 filter elements inside, APS printer connection set, user's guide, power cord in compliance with regional power
Product weight	209 lb/95 kg plus tube connections
Package weight	253 lb/115 kg
Product dimensions	14.3 x 31.5 x 31.3 in 365 x 801 x 797 mm
Package dimensions	22.4 x 35.4 x 44.8 in 570 x 900 x 1140 mm
Power consumption	1600 watts
Fan power	12713 ft ³ /hr (360 m ³ /hr)

HP Designjet High Speed Dryer	
What's in the box	Dryer unit, support stay, foot with castor (2), stand (2), M5 x 12L hexagon socket head bolt (16), hexagon bar wrench, user's guide, power cord in compliance with regional power connections
Product weight	88 lb/40 kg
Package weight	132 lb/60 kg
Product dimensions	95.1 x 24 x 35.5 in 2416 x 612 x 903 mm
Package dimensions	99.6 x 27 x 13 in 2530 x 690 x 335 mm
Power consumption	2750 watts

HP Designjet 8000s Take-Up Reel Kit	
What's in the box	Take-up reel unit, take-up reel sub-unit, plate assembly right, plate assembly left, IR-LED assembly, tension roller assembly, attachment flange, paper tube, clamp guide (2), washer (3), M5x10 screws (9), cable assembly, installation guide
Product weight	55 lb/25 kg
Package weight	63.9 lb/29 kg
Product Dimensions	78.7 x 19.7 x 27.6 in 2000 x 500 x 700 mm
Package dimensions	78.7 x 29.2 x 16.9 in 2000 x 472 x 430 mm
Maximum media roll weight	52.9 lb/24 kg

Ordering information	
Product	Q6670A HP Designjet 8000sr Printer
Accessories	Q6669B Onyx [®] PosterShop [®] 7.0 for HP Designjet Q6668E HP Designjet Air Purifier System 220V Q6668F HP Designjet Air Purifier System 110V Q6681A HP Designjet 8000s Take-up reel Kit Q6667A HP Designjet High Speed Dryer Q6682A HP Designjet 8000s Cutter Blade Kit Q6710A HP Designjet Air Purifier System Filter
Service & Support care packs	UE157A/E 3 year Next-Day Onsite - onsite next day support UE158A/E 4 year Next-Day Onsite - onsite next day support UE159A/E 5 year Next-Day Onsite - onsite next day support UE160A/E 3 year 9x5 Same-Day Onsite - onsite support in 4 hours UE161A/E 4 year 9x5 Same-Day Onsite - onsite support in 4 hours UE162A/E 5 year 9x5 Same-Day Onsite - onsite support in 4 hours UE163A/E 3 year 13x5 Same-Day Onsite - onsite support in 4 hours UE164A/E 4 year 13x5 Same-Day Onsite - onsite support in 4 hours UE165A/E 5 year 13x5 Same-Day Onsite - onsite support in 4 hours UE166PA/E 9x5 Next day onsite - 1 Year post warranty UE167PA/E 9x5 Same-day onsite - 1 Year post warranty UE168PA/E 13x5 Same-day onsite - 1 Year post warranty
Ink supplies	
Cartridges	CB285A HP 780 Black Ink Cartridge, 500 ml CB286A HP 780 Cyan Ink Cartridge, 500 ml CB287A HP 780 Magenta Ink Cartridge, 500 ml CB288A HP 780 Yellow Ink Cartridge, 500 ml CB289A HP 780 Light Cyan Ink Cartridge, 500 ml CB290A HP 780 Light Magenta Ink Cartridge, 500 ml
Waste Ink Bottle	CB291A HP 780 Waste Ink Bottle
Maintenance Kits	CB301A HP 780 Wiper Cleaning Kit CB302A HP 780 Cap Cleaning Kit CB303A HP 780 Ink System Cleaning Kit CB308A HP 780 Ink System Storage Kit
Media supplies	Q8678A HP Premium Scrim Banner 36 in x 164 ft/914 mm x 50 m Q8679A HP Premium Scrim Banner 54 in x 100 ft/1372 mm x 30.5 m Q8680A HP Universal Scrim Banner 36 in x 164 ft/914 mm x 50 m Q8681A HP Universal Scrim Banner 54 in x 100 ft/1372 mm x 30.5 m Q8682A HP Premium Self-adhesive Vinyl 54 in x 150 ft/1372 mm x 45.7 m Q8683A HP Premium Self-adhesive Vinyl 60 in x 150 ft/1524 mm x 45.7 m Q8684A HP Premium Backlit Film 36 in x 66 ft/914 mm x 20.1 m Q8685A HP Premium Backlit Film 54 in x 66 ft/1572 mm x 20.1 m Q8686A HP Universal Photo-realistic Paper 36 in x 150 ft/914 mm x 45.7 m Q8687A HP Universal Photo-realistic Paper 54 in x 150 ft/1372 mm x 45.7 m
Media supplies (available March 07)	Q8782A HP Blue Back Satin Billboard Paper 54 in x 200 ft/1372 mm x 61 m Q8832A HP Blue Back Satin Billboard Paper 64 in x 200 ft/1626 mm x 61 m Q8838A HP Satin Canvas 36 in x 49 ft/914 mm x 14.9 m Q8783A HP Satin Canvas 54 in x 49 ft/1372 mm x 14.9 m Q8833A HP Satin Canvas 60 in x 49 ft/1524 mm x 14.9 m Q8781A HP Translucent PVC Display Film 36 in x 100 ft/914 mm x 30.5 m Q8830A HP Translucent PVC Display Film 54 in x 100 ft/1372 mm x 30.5 m Q8831A HP Translucent PVC Display Film 60 in x 100 ft/1524 mm x 30.5 m Q8775A HP Universal Scrim Banner 64 in x 100 ft/1626 mm x 30.5 m

More HP media sizes available at www.hp.com/go/designjet/supplies